

# Wiring Diagram

# 20

RGB  
24V DC  
DMX Dimming  
AQS-500 & 510

# Wiring Diagram

## 4 Wire Fitting - LT903 DMX - 24V DC

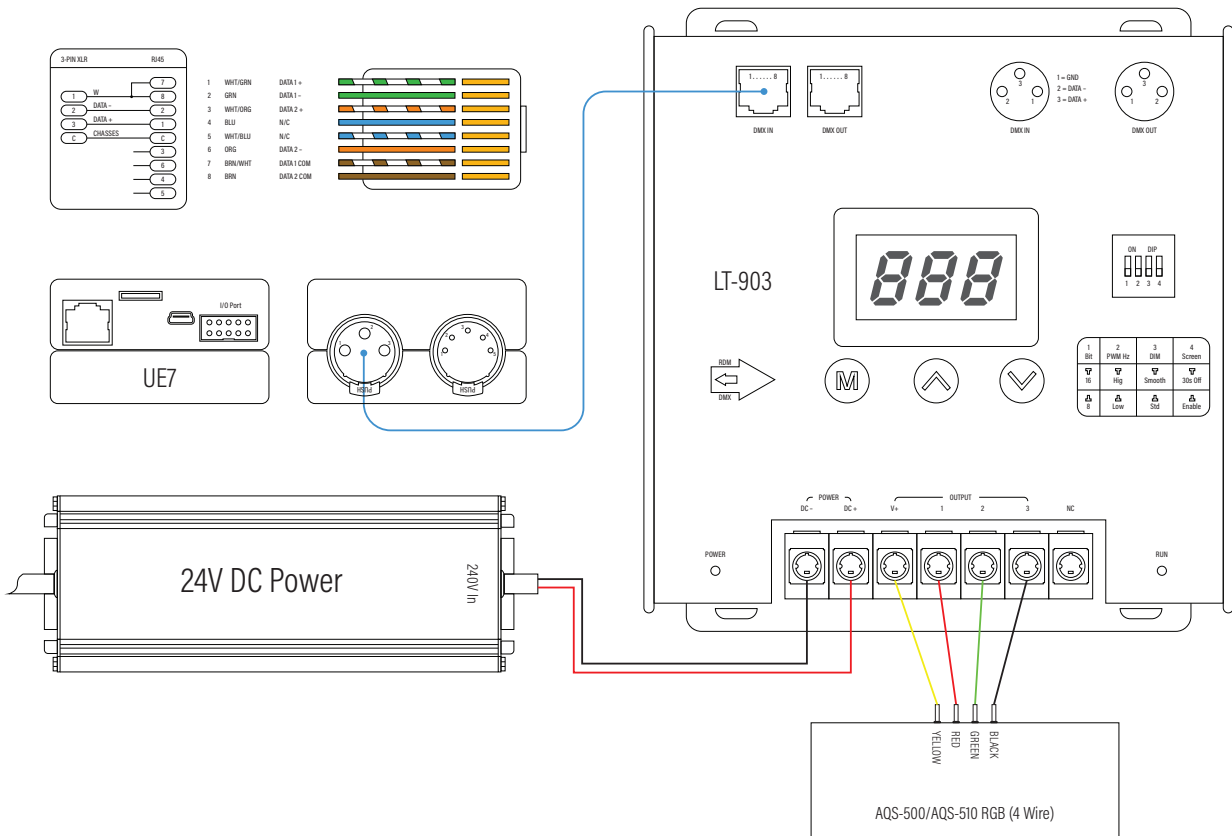

Setup allows for app control (needs to be on a wifi network), calendar scene triggers, operation from control systems and scene triggering from external sources. 12 and 24 channel receivers also available. Receivers can be daisy chained. Up to 170 individual runs of neon flex per DMX universe with the appropriate amount of receivers. Up to 2 DMX Universes. Wall Controllers available. Max 10m strip run for single end feed and 20m double end feed.