

Wiring Diagram

19

RGBW
24V DC
DMX Dimming
AQS-500 & 510

Wiring Diagram

5 Wire Fitting - LT904 DMX - 24V DC

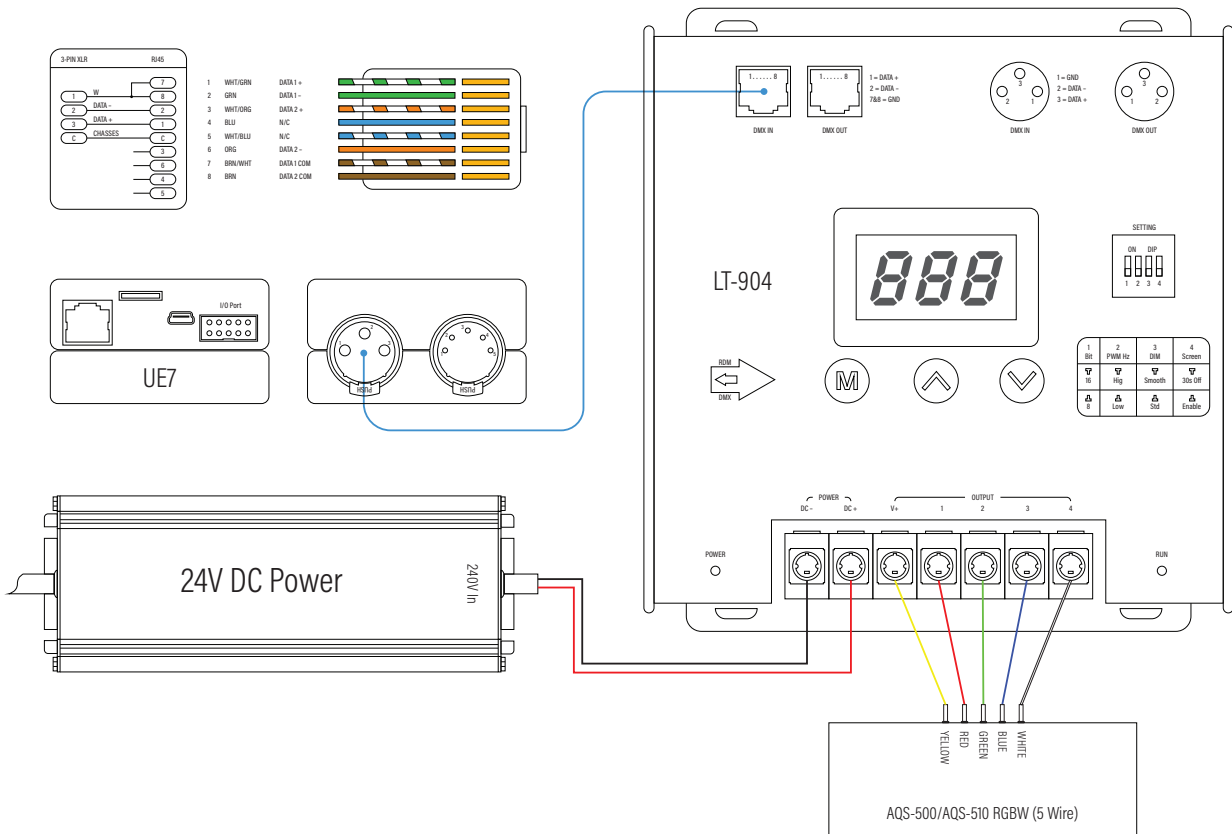

Setup allows for app control (needs to be on a wifi network), calendar scene triggers, operation from control systems and scene triggering from external sources. 16 and 32 channel receivers available. Receivers can be daisy chained. Up to 128 individual runs of neon flex per DMX universe with the appropriate amount of receivers. Up to 2 DMX Universes. Wall Controllers available. Max 10m strip run for single end feed and 20m double end feed.